



EF800 - SELF CONTAINED FLAKE ICE MAKER



EF800

Features

- Produces up to 772 lbs (350 kg) of ice per day.
- Constructed with a rugged stainless steel transport system enclosed in polyurethane insulation.
- Removes excess water by pushing the flaked ice through an extrusion process – the result is high-quality flaked ice which is ideal for medical, supermarket or restaurant applications.
- Constructed from sturdy, corrosion-resistant stainless steel.
- Filter-Free Air – no air filter to change.

Options & Accessories

WATER FILTERS			
Ice Machine Model	Manifold		Inline
	System	Replacement	System
EF800	IFQ1	IOMQ (1)	IFI4C / IFI8C

Ice Maker Warranty

Every Ice-O-Matic ice maker is backed by a warranty that provides both parts and labor coverage.

- Two years **Parts** and **Labor**.
- Five years **Parts** coverage on the evaporator and compressor.

Ice Form



FLAKED ICE

Space-Saving Solutions

- Self-contained insulated storage available in 213 lbs (97 kg) or 315 lbs (143 kg).
- Your choice of 38" (965 mm) or 48" (1219 mm) wide cabinets.
- Ultra-low profile – 41" (1041 mm) tall.
- Air intake on only one side.

EF800 SELF CONTAINED FLAKE ICE MAKER



EF800 - SELF CONTAINED FLAKE ICE MAKER

EF800 SELF CONTAINED FLAKE ICE MAKER

Air Cooled

Please note: air-cooled units require 6" (152 mm) clearance for air intake and exhaust.

- A. Ice maker potable water in, 3/8" FPT.
- B. Drain, 1/2" i.d. plastic tubing.
- C. Hole for electrical connections.
- D. 3/4" bin drain.

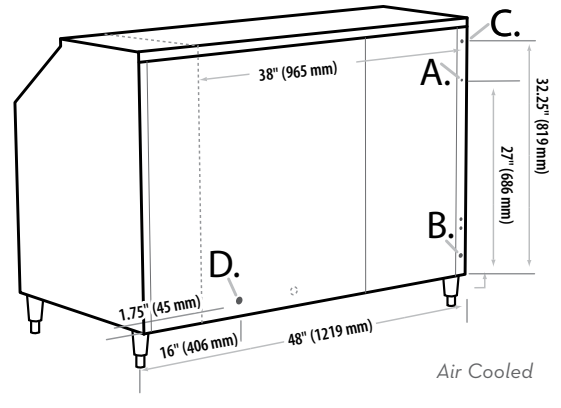
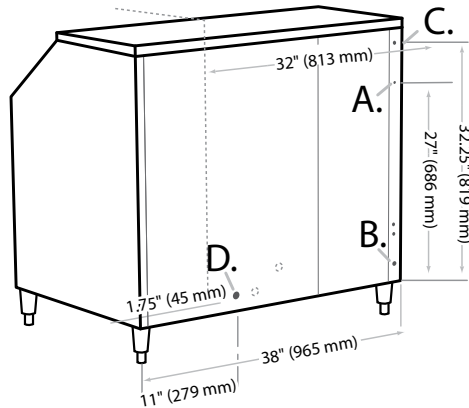
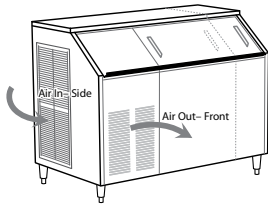

Air Cooled

Operating Requirements

	MINIMUM	MAXIMUM
	60 Hz	
Ambient Temp. Range Air	50 °F (10 °C)	100 °F (38 °C)
Water Temp.	40 °F (4.4 °C)	80 °F (26.7 °C)
Water Pressure	20 PSIG (1.4 BAR)	60 PSIG (4.1 BAR)

Dimensions

MODEL	W x D x H (in.)	W x D x H (mm)
EF800A38S	38 x 28 x 41	965 x 711 x 1041
EF800A48S	48 x 28 x 41	1219 x 711 x 1041

Specifications

Model Number	Cabinet Width in. (mm)	Bin Size lbs (kg)	Cond. Unit	Ice Production per 24 hrs		Water Usage gallons per 100 lbs of ice @ 90°F air/70°F water	kWH Used per 100 lbs of ice @ 90°F air/70°F water	Voltage Characteristics	Min. Circuit Ampacity	Fuse Size	Approx. BTUs per hour
				70°F air/50°F water lbs (kg)	90°F air/70°F water lbs (kg)						
EF800A38S	38 (965)	213 (97)	Air	772 (350)	616 (279)	12	4.6	115/60/1	18.2	20	7,460
EF800A48S	48 (1219)	315 (143)		772 (350)	616 (279)	12	4.6	115/60/1	18.2	20	7,460

NOTES:
 Number of Wires: 3 (including ground)
 Approx. Shipping Weight lbs (kg): EF800A38S 290 (132) • EF800A48S 325 (142)
 Refrigerant Type: R404A